

EXTRACTOR-SE

Inline magnet for protecting extruders,
injection moulding and blow moulding
machinery

- For applications in the plastics industry
with slow moving bulk material columns
- Easy handling and cleaning
- Great variety of application possibilities
(exchangeable transition ring)



- Outstanding magnetic power
- Highest magnetic performance with 800 mT (8 000 gauss) on the effective surface
- Stainless steel housing (AISI 304)
- Neodymium magnet rods in EASY CLEAN design
- Arranged in a triangular matrix
- Sturdy design
- Low installation height (165 mm)
- Options and accessories



Design example of the EXTRACTOR-SE with slidegate.

Performance characteristics:

The EXTRACTOR-SE magnet system is equipped with three magnet rods in Neodymium version which are arranged in a triangular matrix to ensure best possible contact between product and magnet. Its outstanding ease of handling and cleaning are further positive features of this magnet separator. A low installation height (165 mm) and customer-specific connection dimensions facilitate retrofitting. The magnet separator is of a highly sturdy design and is able to take static loads of up to 500 kg (shear load up to 50 kg). With its special design the EXTRACTOR-SE does not allow any depositing of plastic granulate (which is important in case of a colour or material change). By using adapting plates the EXTRACTOR-SE magnet system can be easily integrated in all kinds of systems. A replaceable transition ring allows the installation on all inlet sizes up to a diameter of 120 mm without modifying the design of the EXTRACTOR-SE.

Functions:

With a magnetic force of 800 mT (8 000 gauss) on the effective surface, ferromagnetic particles are reliably separated, which reduces costly repair work and system downtimes.

Typical applications:

The EXTRACTOR-SE inline magnet was developed specifically for applications in the plastics industry. It is designed for inspecting different granulates up to a grain size of 8-10 mm at a temperature of up to 80° C in slow-moving material columns.

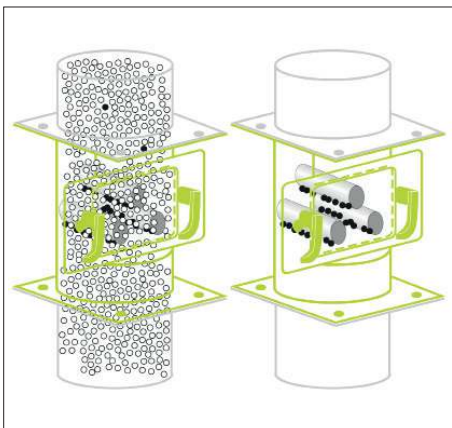

The EXTRACTOR-SE inline magnet is used in slow moving material columns.

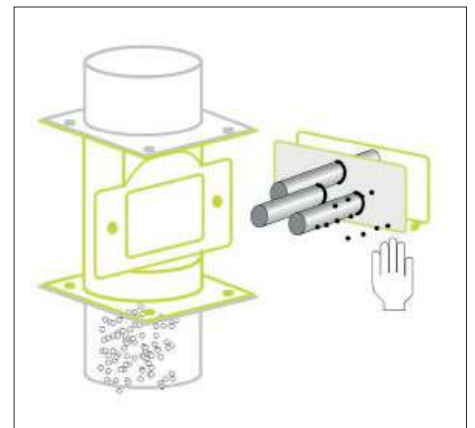

After the magnet matrix has been removed, the stainless steel tubes can be pulled off from the magnet cores – EASY CLEAN.