

T4000 Case System



T4000 Case System

Vacuum or pressure inspection for metal cans or glass jars with metal closures that are sealed in cardboard or shrink wrapped cases.

Case Inspection for Metal Cans or Glass Jars with Metal Closures

The T4000 Case system is designed for non-contact, non-destructive, 100% automatic container inspection through a sealed cardboard and/or shrink wrapped case. The system offers the option of acoustic or proximity technology to inspect glass jars with metal closures or metal cans for pressure or vacuum after the containers have been sealed in the case. In many applications, the T4000 Case system will detect defects other than low pressure or vacuum. Some examples are missing containers, containers with missing lids or broken bottles, flat sours and damaged cans.

Features

- 100% non-contact inspection
- Large PC touch screen
- Graphic screen shows defects in case
- Acoustic and Proximity sensor heads (up to 4 heads)
- Quick set sensor bridge for easy product changeover
- Speeds up to 250 cases per minute
- NEMA 4x, stainless steel, water wash down (user interface enclosure and control enclosure)

Applications

- Vacuum/Pressure inspection in metal cans
- Vacuum/Pressure inspection in glass jars with metal closures
- Missing cans
- Broken or missing glass bottles

How It Works

Acoustic Technology

Acoustic technology works by applying an electromagnetic pulse or "tap" to the top of each container inside the sealed cardboard or shrink wrapped case. The lid of the container vibrates at a natural resonant frequency ("tone") based on the internal pressure or vacuum in the container. A microphone then senses the resultant tone. The system converts the analog signal to digital and then the DSP board analyzes the output and calculates the frequency. Containers outside user-set limits result in the entire case being rejected. The magnetic pulse and acoustic response will work through the cardboard or shrink wrapped cases. Defects include low or no vacuum, low or no pressure, flat sours, dented lids and missing containers in the case.

Proximity Technology

Proximity technology works by measuring the curvature of each container through the sealed case using analog proximity sensors. The curvature for each container in the case is analyzed and assigned a merit value based on the curvature measurements. The system determines whether the container is acceptable or faulty based on user-set parameters. Containers outside user-set limits result in the entire case

being rejected. The analog sensor will work through the cardboard or shrink wrapped cases. Defects include low or no vacuum, Low or no pressure, swelled cans, pop-buttons, dented seams or missing containers inside the cases.

Case System Configuration

The T4000 Case system is a self-standing system that can be configured as follows:

- Proximity inspection: 1-4 proximity sensor heads (single bridge)
- Acoustic inspection: 1-4 acoustic sensor heads (single bridge)
- Combined acoustic/proximity inspection (one acoustic bridge and one proximity bridge)

The system includes a six-foot inspection conveyor for warehouse or other off-line applications. Spray markers can also be added (optional) to mark the location of the faulty containers within the case for easy identification and rework. The system can be ordered without the conveyor for on-line applications.

SYSTEM SPECIFICATIONS

PC User Interface

Power Requirements:	100-240 VAC, 50-60 Hz, 1-phase, 90 Watts
Material / Rating:	Enclosure: 304 Stainless steel, NEMA 4X, IP65
Display:	Watertight LCD color touch screen PC, 25.4 cm (10 in.)
Mounting:	Angled pedestal stand, 304 stainless steel
Operating Conditions:	Stable ambient temperature: 0° - 50° C (32° - 122° F) Relative humidity: 0-90%, non-condensing Altitude: Sea level to 3,035 m (10,000 feet)

T4000 Case System

Electronics Enclosure

Power Requirements:	100-240 VAC, 50-60 Hz, 1-phase, 275 Watts
Material / Rating:	Enclosure: 304 Stainless steel, NEMA 4X, IP65
Mounting:	Bracket mount to conveyor side rail
Operating Conditions:	Stable ambient temperature: 0° - 50° C (32° - 122° F) Relative humidity: 0-90%, non-condensing Altitude: Sea level to 3,035 m (10,000 feet)

Conveyor

Power Requirements:	110-125 VAC, 60 Hz, 1-phase, 1500 Watts (or) 220 VAC to 240 VAC 50 Hz, 1-phase, 1500 Watts
Inspection Speed:	Maximum belt speed: 91.4 m/min (300 ft/min)
Bridge Specification:	Maximum case height: 260 mm (10.25 in.) Maximum case width: 406 mm (16.0 in.) Minimum container diameter: 45 mm (1.8 in.)
Bridge Materials:	ABS plastic, hard coat anodized aluminum

T4000 Case System

User Interface

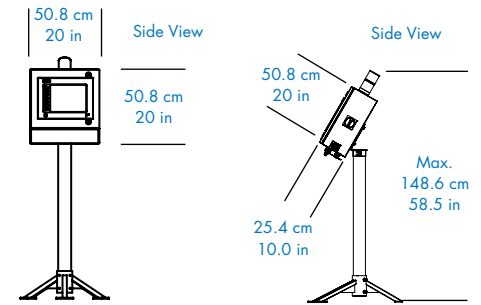

Sensor mounting

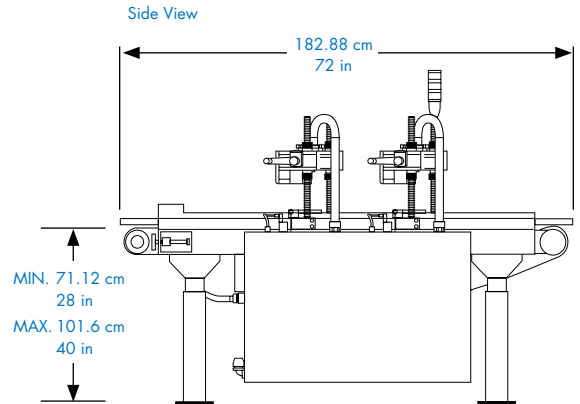

T4000 Case System | Options

Rejector: 200mm (8 inch) stroke rejector - Pneumatic ram style rejector with adjustable stroke. The rejector's maximum displacement is 200mm (8 inches).

Spray marker system: Marks the location of defective containers on the outside of the case for easy identification and rework.



49 Edgerton Drive • North Falmouth, MA 02556 USA

P: +1 508.563.1000

F: +1 508.564.9945

E-Mail: taptone@teledyne.com