

We Build Confidence...

In Label Application

The Labeljet 210 is a modern, microprocessor controlled, industrial label applicator. The integral stepper motor drives the label web at up to 98 feet per minute (30 m/min.). A shaft encoder input (for speed compensation) is standard, and optional application methods include tamp and blow modules.

- *Fast and accurate*
- *Simple operation*
- *Low maintenance*
- *High speed*
- *Microprocessor control*
- *Stepper motor*
- *Storage of multiple production settings*

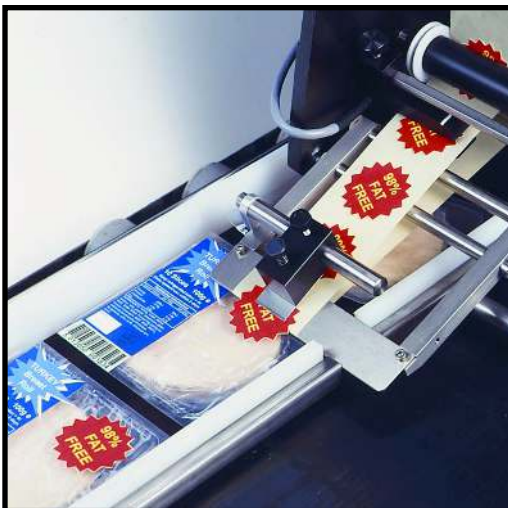

Get confident. Contact us today.

We Build Confidence...

Specifications

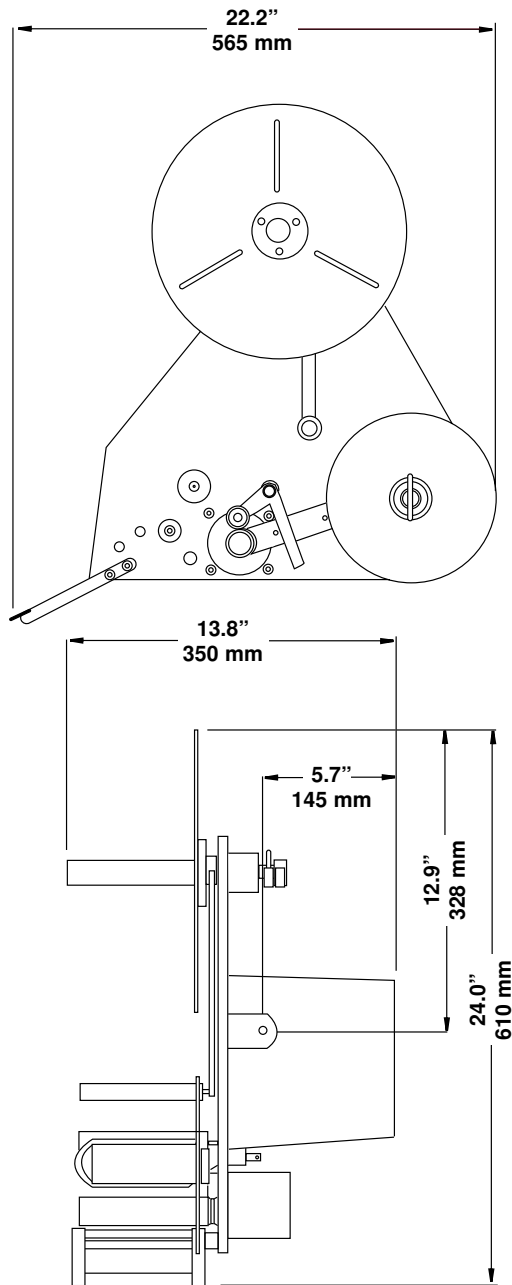

Left - hand orientation shown

Standard Features:

- Label size: Min 0.5" (W) 0.5" (L) (12 mm x 12 mm)
Max: 4.0" (W) x 19.7" (L) (104 mm x 500 mm)
- Direction: left or right-hand
- Accuracy: better than ± 0.04 " (1mm)
- Speed range: 6.6 feet to 98.4 feet/min. (2 m to 30 m/min.) variable
- Unwind capacity: 11.8" (300 mm) diameter (15.7" / 400 mm optional)
- LCD display with language-independent icons
- Setup functions for: web speed, label stop, label sensitivity, product delay and coder dwell
- 10 memory storage locations
- 3" (76 mm) core diameter
- Control console

Standard Inputs:

- Product detector
- Shaft encoder
- Dual photocell

Standard Outputs:

- Lamp stack
- Tamp/blow
- Alarm
- Hot stamp
- Air assist

Options:

- Mounting stand
- Product detector
- Blow module
- Shaft encoder
- Alarm stack
- Tamp module

Electrical Requirements:

- 230 or 110 VAC 50 - 60Hz
- 250VA

Weight:

- 50.8 lbs (23 kg)

Environment:

- 32° to 113°F (0° to 45°C)

Approvals:

CE TÜV

© 2003 Videojet Technologies Inc. - All rights reserved. Videojet Technologies Inc.'s policy is one of continued product improvement. We reserve the right to alter design and/or specifications without notice. Labeljet is a trademark and Videojet is a registered trademark of Videojet Technologies Inc.



800-843-3610 • www.videojet.com • info@videojet.com

Videojet Technologies Inc. • 1500 Mittel Boulevard
Wood Dale IL • 60191-1073 • USA
Phone: 630-860-7300 • Fax: 630-616-3623

Part No. SL000385
Labeljet 210-0703-US
Printed in U.S.A.