



Continuous Ink Jet

1650 Ultra High Speed

Higher throughput targets, increasing regulatory and supply chain needs, and greater focus on operational efficiency all equate to increased demands on your production lines.

Superior speed in itself is worthless without high quality, accurate coding and high uptime. The Videojet 1650 UHS delivers against the demands on your production lines through a unique combination of design and advanced ink formulations. Combining the ultimate in print speed, the most innovative printhead technology, and the advanced CLARiTY™ interface, the Videojet 1650 UHS allows you to deliver more product with more code content – all while making sure the right code gets printed on the right product.



High quality coding at high speeds

- Videojet's Precision Ink Drop™ system provides precise character formation, even at the highest speeds and longer throw distances
- Dynamic Calibration™ adjusts jetting parameters automatically to ensure high quality print
- Superior technology enables you to add content without compromising speed
 - Single line max speed = 1666 ft/min (508m/min)
 - Dual line max speed = 694 ft/min (212m/min)
 - Tri-line max speed = 588 ft/min (179m/min).

Engineered for extended runs

The Videojet 1650 UHS gives you an uptime advantage via:

- CleanFlow™ technology resists ink buildup that can cause ordinary ink jet printers to shut down
- Long run time between preventive maintenance, up to 14,000 hour core life
- Internal pump means no external air, minimizing potential for contaminants to enter ink stream
- Auto cleaning printhead for fast start-ups even after extended shutdowns.

Simple usability via an advanced user interface

- Productivity tools give you standard OEE metrics backed by actionable data
- Fool proof data entry helps you get the right code, in the right place, at the right time, virtually eliminating errors
- Large, responsive 10.4" touchscreen with intuitive navigation simplifies operation and makes key data easily visible.

Videojet® 1620 Ultra High Speed Continuous Ink Jet

Line speed capability

Can print 1 to 4 lines of print at speeds of up to:
Single line max speed = 1666 ft/min (508m/min)
Dual line max speed = 694 ft/min (212m/min)
Tri-line max speed = 588 ft/min (179m/min)
(10 characters per inch, single line of print)

Font matrix configuration

Single-line: 4x5, 5x5, 4x7, 5x7, 10x16
Twin-line: 4x5, 5x5, 4x7, 5x7, 7x9
Tri-line: 4x5, 5x5, 4x7, 5x7
Quad-line: 4x5, 5x5

Linear bar codes*

UPC A&E; EAN 8 & 13; Code 128 A, B & C; UCC/EAN 128;
Code 39; Interleaved 2 of 5; 2D DataMatrix; GS1

DataMatrix codes*

10x10, 12x12, 14x14, 16x16, 8x18, 12x36, 16x36, 16x48, 16x26, 8x32

Nominal character height

Selectable from 0.039" to 0.307" (1mm to 7.8mm), depending on font

Throw distance

Optimal: 0.394" (10 mm)
Range: 0.197" to 0.787" (5mm to 20mm)

User interface

10.4" high-response TFT-LCD touch screen
WYSIWYG touch to edit message editing

Custom logo/graphics

Can be created via optional CLARISOFT® software

Character sets

Chinese, Russian/Bulgarian, Turkish/Scandinavian, Greek, Arabic, Japanese/Kanji,
Hebrew, Korean, East European and European/American

Languages and interface options

English, Arabic, Bulgarian, Czech, Danish, Dutch, Finnish, French, German, Greek, Hebrew,
Hungarian, Italian, Japanese, Korean, Norwegian, Polish, Portuguese, Russian, Simple
Chinese, Spanish, Swedish, Thai, Traditional Chinese, Turkish and Vietnamese

Data interface

Ethernet (standard)
Clarisoft/Clarinet® via ethernet
Message management via USB

Message storage

More than 250 complex messages

Environmental protection

IP65 standard, no plant air required; 316 stainless steel cabinet

Printhead

Heated printhead
Positive air (standard)
Nozzle size: 50 micron
Diameter: 1.63" (41.3mm)
Length: 10.62" (269.8mm)

Printhead umbilical

Ultra flexible
Length: 9.84' (3m) optional 19.69' (6m)
Diameter: 0.91" (23mm)
Bend radius: 4.0" (101.6mm)

Make-up fluid consumption

As low as 2.4 ml/hour

Fluids containers

Ink smart cartridge™ 0.793qt. (750ml)
Make-up smart cartridge 0.793qt. (750ml)
Ink bulk system 5.28qts. (5 liters)
Make-up bulk system 5.28qts. (5 liters)

Temperature/humidity range

32°F to 113°F (0°C to 45°C)
0% to 90% RH non-condensing
With selected inks; actual installation may require additional hardware
based on production environment conditions

Electrical requirements

Nominal supply power 100-120 / 200-240 VAC at 50/60 Hz,
120W peak maximum, 60W nominal

Approximate weight

Unpacked and dry: 48.5lbs. (22kg)

Options

Dry air kit for high humidity (requires plant air)
Wide range of accessories

* CLARISOFT Package Coding Design software required for bar codes
and other advanced functionality.

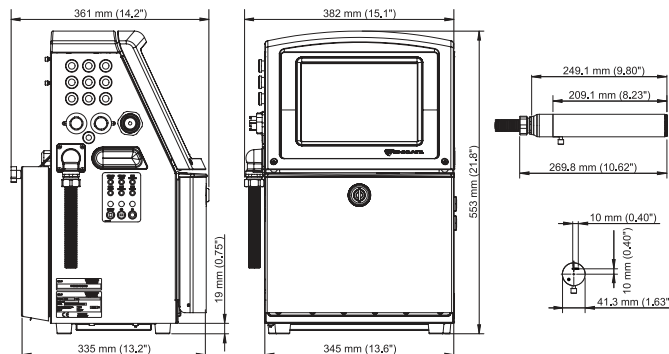

Call **800-843-3610**

Email **info@videojet.com**

or visit **www.videojet.com**

Videojet Technologies Inc.

1500 Mittel Blvd. Wood Dale IL 60191 / USA

©2013 Videojet Technologies Inc. — All rights reserved.

Videojet Technologies Inc.'s policy is one of continued product improvement. We reserve the right to alter design and/or specifications without notice. TrueType is a registered trademark of Apple Computer, Inc.

Videojet® 1000 Line Continuous Ink Jet Printers.

Part No. SL000562. 1650 UHS Spec-0213. Printed in U.S.A.

